

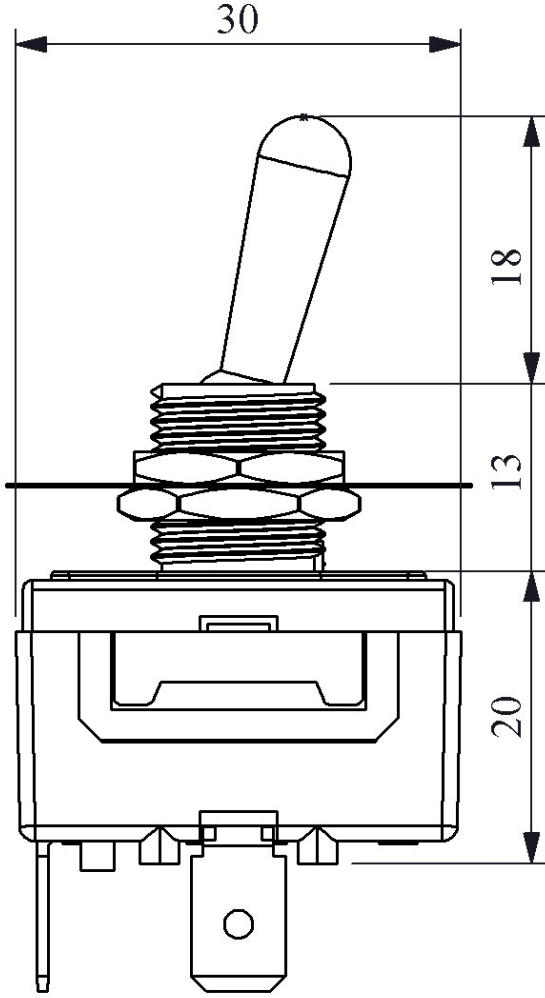

MA111TT

Product	Toggle Switch
Serial	MA Series
Contact	1NO
Connection Type	with Terminal
Feature	with Black Label
Print	(On-Off) Marked
Current	I_e 16 A (250V AC)
Usage Category	AC15
Mechanical Life (Min Qty)	100000
Electrical Life (Min Qty)	10000
Operating Frequency (On-Off/Hour)	Mech.900 Elec.900
Insulation Voltage (U _i)	300V
Impulse Withstand Voltage (U _{imp})	2.5 kV
Dielectric Strength (Body-Contact)	2.500V AC
Dielectric Strength (Contact-Contact)	1.500V AC
Isolation Resistance	10 MΩ min. (500V DC)
Operating Temperature	-25 / +80 °C
Pollution Degree	3
Protection Degree	IP20
Contact Material	AgNi
Cable Section	Terminal 6,3*0,8 mm
	1 kA
Specifications	V0 material
Standards / Certificates	TS EN 61058-1





Devre Şeması

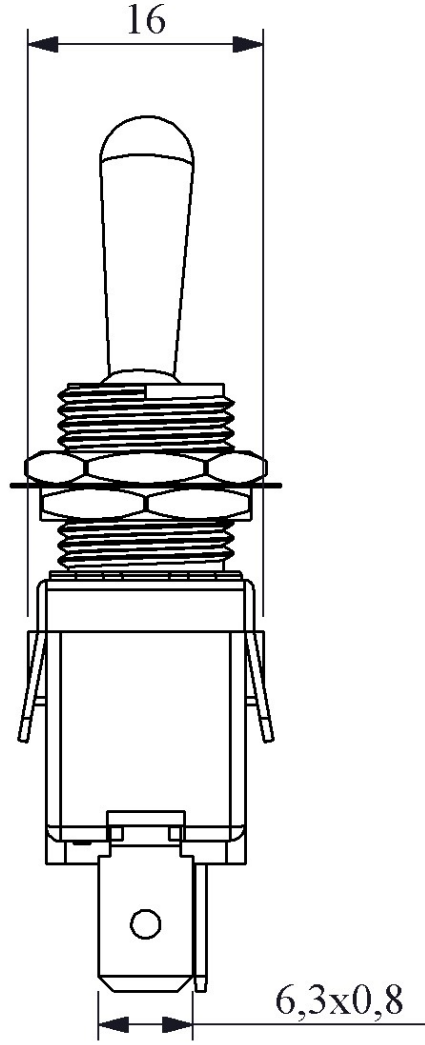
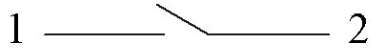

Montaj Ölçüsü ϕ 12 mm