

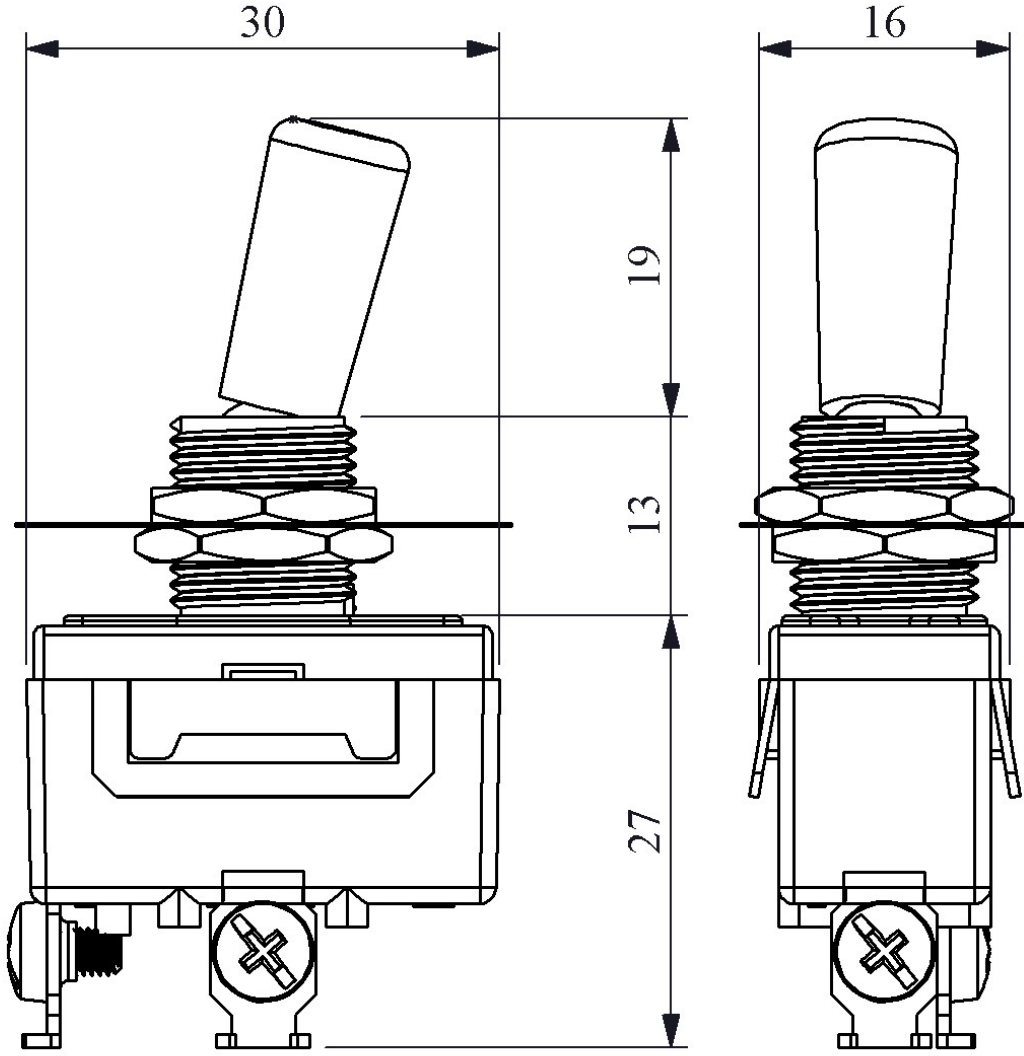

<b>MA211</b>	
<b>Product</b>	Toggle Switch
<b>Serial</b>	MA Series
<b>Contact</b>	2NO
<b>Connection Type</b>	with Screw
<b>Print</b>	(On-Off) Marked
<b>Current</b>	<b>I<sub>e</sub></b> 16 A (250V AC)
<b>Usage Category</b>	AC15
<b>Mechanical Life (Min Qty)</b>	100000
<b>Electrical Life (Min Qty)</b>	10000
<b>Operating Frequency (On-Off/Hour)</b>	Mech.900 Elec.900
<b>Insulation Voltage (U<sub>i</sub>)</b>	300V
<b>Impulse Withstand Voltage (U<sub>imp</sub>)</b>	2.5 kV
<b>Dielectric Strength (Body-Contact)</b>	2.500V AC
<b>Dielectric Strength (Contact-Contact)</b>	1.500V AC
<b>Isolation Resistance</b>	10 MΩ min. (500V DC)
<b>Operating Temperature</b>	-25 / +80 °C
<b>Pollution Degree</b>	3
<b>Protection Degree</b>	IP20
<b>Contact Material</b>	AgNi
<b>Cable Section</b>	1-2.5 mm <sup>2</sup>
<b>Screw Torque</b>	1,5 Nm
	1 kA
<b>Specifications</b>	V0 material
<b>Standards / Certificates</b>	TS EN 61058-1



Devre Şeması

Montaj Ölçüsü  $\varnothing$  12 mm

1 ———— 2