



### PDM11

Carton Box pieces	<b>Qty</b>	1
Product		Foot Switch
Model		with 1mt Cable
Contact		1CO
Color		Black
Current	<b>Ie</b>	6 A (250V AC)
Usage Category		AC 15
Mechanical Life	<b>Min Qty</b>	1000000
Electrical Life	<b>Min Qty</b>	100000
Operating Frequency	<b>On-Off/Hour</b>	Mech. 1800 Elec. 1200
Insulation Voltage	<b>Ui</b>	660V
Impulse Withstand Voltage	<b>Uimp</b>	2.5 kV
Dielectric Strength (Body-Contact)		2.500V AC
Dielectric Strength (Contact-Contact)		1.890V AC
Isolation Resistance		10 MΩ min. (500V DC)
Operating Temperature		-25 / +80 °C
Pollution Degree		3
Protection Degree		IP20
Contact Material		AgNi
Cable Section		1.5-2.5 mm <sup>2</sup>
Screw Torque		1.5Nm
Short Circuit Breaking Capacity	<b>Ics</b>	1 kA
Body Material		Plastic
Production Time		31.12.1899 00:00:00
Serial		PDM Series
Specifications		Plastic
		Single speed
Standards / Certificates		TS EN 60947-5-1

CE



UK  
PK

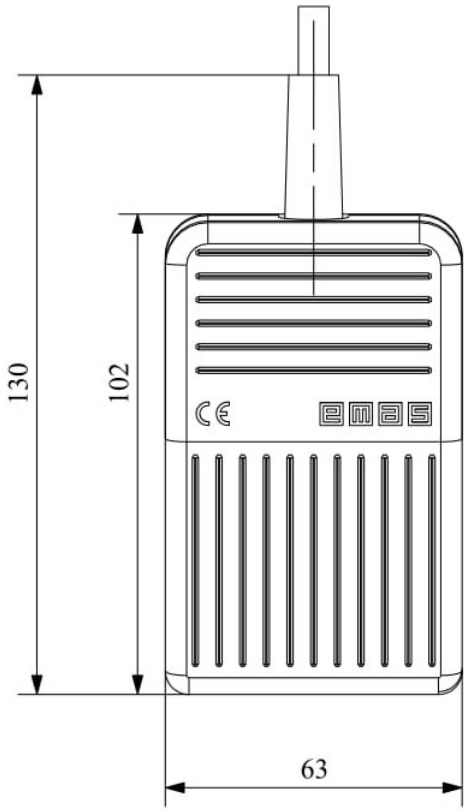

PDM11

