

SK5P
Product Level Control Float Switch

Type Plastic Float

Phase Number 1 Phase

Current **I_e** 3 A (240V AC)

Usage Category AC15

Mechanical Life **Min Qty** 30000

Electrical Life **Min Qty** 10000

Operating Frequency **On-Off/Hour** Mek.120 Elk.120

Insulation Voltage **U_i** 300 V

Impulse Withstand Voltage **U_{imp}** 2,5 kV

Dielectric Strength (Body-Contact) 2.500V AC

Dielectric Strength (Contact-Contact) 1.500V AC

Isolation Resistance 10 MΩ Min. (500 V DC)

Operating Temperature -15 / + 80 °C

Pollution Degree 3

Protection Degree IP65

Contact Material AgNi

Cable Section 1.5-2.5 mm²
Screw Torque 1.5Nm

Serial SK5 Series

Specifications

- Easy assembly
- Feature to adjust the requested operation interval with weight
- Different cable length options
- Waterproof

Standards / Certificates TS EN 60730-2-15

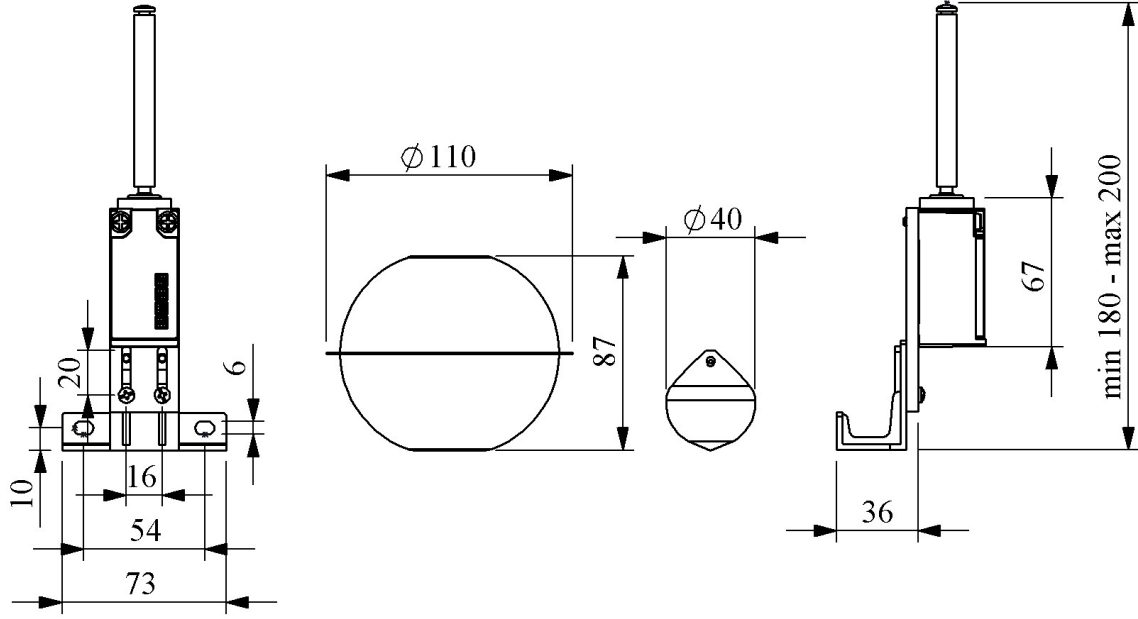
Devre Şeması

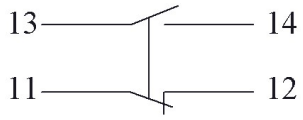

Ani Hareketli