

**TSP-2.50**

Çalışma Frekansı		50-60 Hz
Ürün		Termik Şalter
Özellik		Kutulu
Kontakt Akımı	<b>Ie</b>	16 A
Termik Akım Ayar Aralığı		1,50-2,50A
Kullanım Kategorisi		AC 3
Mekanik Ömür	<b>Min Adet</b>	10000
Elektriksel Ömür	<b>Min Adet</b>	10000
Çalışma Sıklığı	<b>Açma Kapama/Saat</b>	Mek. 360 Elk. 360
Yalıtım Gerilimi	<b>Ui</b>	690V AC
Darbe Dayanım Gerilimi	<b>Uimp</b>	6 kV
Dielektrik Mukavemeti (Kontakt-Kontakt)		1890V
İzolasyon Direnci		10 MΩ Min. (500 V DC)
Çalışma Sıcaklığı		-5 / +40 °C
Kirlenme Derecesi		3
Koruma Sınıfı		IP65
Kablo Bağlantı Kesiti		0,75-4 mm <sup>2</sup>
Sıkma Kuvveti		1,8 Nm
İmal Tarihi		
Seri		TS Serisi
Özellikler		0.18 -16 A arasında ayarlanabilen 11 kademeli aşırı akım koruyucusu Mekanik darbelere tam dayanım Etanj özelliği sayesinde çevre şartlarına maksimum dayanım Sıva üstü ve ankastre Kutulu
Standartlar / Belgeler		TS EN 60947-4-1

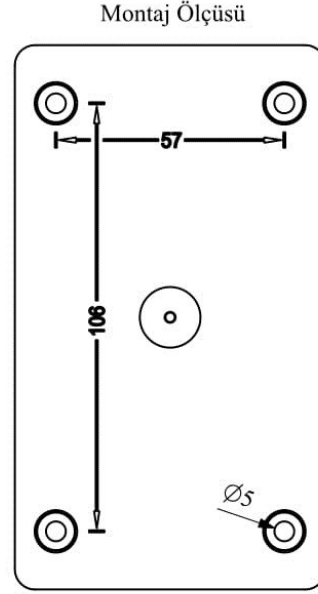

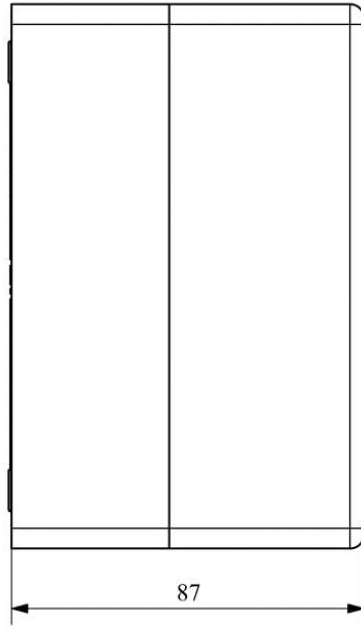
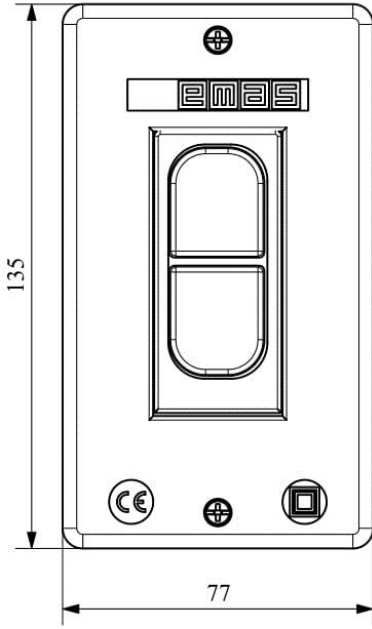

Elektrik Şeması

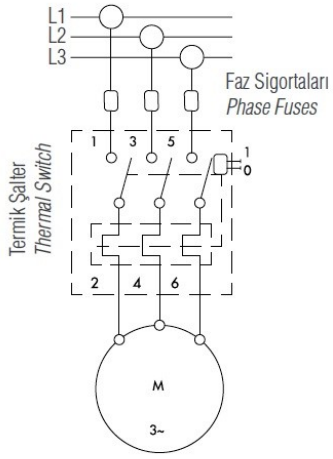

Trifaze Bağlantı

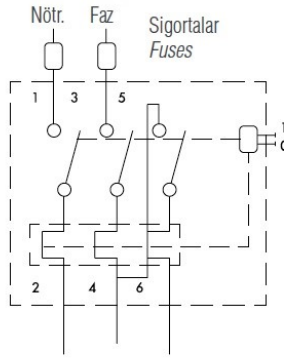

Monofaze Bağlantı